



JIKE
Industry Chains

Indoor WPC wall panel

Wechat/Whatsapp: +8618866930785 Email: andy@jikewood.com

| No. | Items | Photo | Real size | Usage Size | Pcs/ Carton | Carton size | Weight/M | |
|-----|--------------|---|-----------|------------|-------------|-------------|----------|--|
| 1 | 160-24A格栅 |  | 167-24 | 160-24 | 14 | 20.5*18cm | 850 | |
| 2 | 160-24A格栅半包敷 |  | 167-24 | 160-24 | 14 | 20.5*18cm | 850 | |
| 3 | 160-24B格栅 |  | 167-24 | 160-24 | 14 | 20.5*18cm | 780 | |
| 4 | 160-24B格栅半包敷 |  | 167-24 | 160-24 | 14 | 20.5*18cm | 780 | |
| 5 | 160-23格栅 |  | 167-23 | 160-23 | 14 | 20.5*18cm | 820 | |

| No. | Items | Photo | Real size | Usage Size | Pcs/ Carton | Carton size | Weight/M | |
|-----|--------------------|---|-----------|------------|-------------|-----------------|----------|--|
| 6 | 160-20 格栅 |  | 167-20 | 160-20 | 14 | 20.5*19.5 cm | 750 | |
| 7 | 150-17 格栅 |  | 153-17 | 150-17 | 20 | 21.5*16.5 cm | 650 | |
| 8 | 200-20 五格格 栅 |  | 210-20 | 202-20 | 14 | 17.5*22cm | 980 | |
| 9 | 170-18 六格格 栅 |  | 173-18 | 170-18 | 16 | 18.5*19cm | 780 | |
| 10 | 170-17 八格格 栅 |  | 168-17 | 160-17 | 16 | 17.5- 19.5cm | 900 | |

| No. | Items | Photo | Real size | Usage Size | Pcs/ Carton | Carton size | Weight/M | |
|-----|--------------------|---|-----------|------------|-------------|-------------|----------|--|
| 11 | 150-18 圓孔格 柵 |  | 160-18 | 153-18 | 18 | | 750 | |
| 12 | 150-22 圓孔格 柵 |  | 159-22 | 150-22 | 14 | 16.5*18cm | 1000 | |
| 13 | 150-24 圓孔格 柵 |  | 169-24 | 160-24 | 14 | 18*20.5cm | 950 | |
| 14 | 150-15 半圓板 |  | 154-15 | 150-15 | 16 | 24*17cm | 650 | |
| 15 | 150-15 半圓板 |  | 158-15 | 150-15 | 16 | 24*17cm | 680 | |

| No. | Items | Photo | Real size | Usage Size | Pcs/ Carton | Carton size | Weight/M | |
|-----|---------------------|---|---------------|------------|-------------|-----------------|----------|--|
| 16 | 150-9 长城板 |  | 157-9 | 150-9 | 28 | 23.9*16.6 cm | 520 | |
| 17 | 150-10 长城板 |  | 158.5- 10 | 150-10 | 28 | 23.9*16.6 cm | 580 | |
| 18 | 150-8 单筋长 城板 |  | 154.5- 7.8 | 150-8 | 34支 | 16*26cm | 420 | |
| 19 | 152-12 单筋长 城板 |  | 157- 11.5 | 152-12 | 23 | 16.5*27cm | 620 | |
| 20 | 195-12 双筋长 城板 |  | 199-12 | 195-12 | 23 | 27*21cm | 680 | |

| No. | Items | Photo | Real size | Usage Size | Pcs/ Carton | Carton size | Weight/M | |
|-----|-----------------|---|-----------|------------|-------------|-----------------|----------|--|
| 21 | 195-14 双筋长城板 |  | 199-14 | 195-14 | 19 | 27*21cm | 720 | |
| 22 | 195-14 单筋长城板 |  | 199-14 | 195-14 | 19 | 27*21cm | 800 | |
| 23 | 150-8 实心小格栅 |  | 155-8 | 150-8 | 20 | 13*17cm | 650 | |
| 24 | 142-16 实心格栅 |  | 146-16 | 142-16 | 14 | 15.5*14.7 cm | 1050 | |
| 25 | 160-18 实心格栅 |  | 160-18 | 152-18 | 14 | 17*17cm | 1250 | |

| No. | Items | Photo | Real size | Usage Size | Pcs/ Carton | Carton size | Weight/M | |
|-----|----------------|---|-----------|------------|-------------|--------------|----------|--|
| 26 | 195-28 高长城 |  | 202.5-28 | 195-28 | 12 | 20.5*21.5 cm | 1080 | |
| 27 | 195-25 高长城 |  | 202-25 | 195-25 | 14 | 20.5*21.5 cm | 980 | |
| 28 | 168-24 异形板 |  | 180-22 | 168-22 | 12支 | 18.5*29cm | 900 | |
| 29 | 200-9 平槽密拼板 |  | 208-9 | 200-9 | 16支 | 16*21cm | 800 | |
| 30 | 200-9 圆槽密拼板 |  | 208-9 | 200-9 | 16支 | 16*21cm | 800 | |

| No. | Items | Photo | Real size | Usage Size | Pcs/ Carton | Carton size | Weight/M | |
|-----|----------------|---|-----------|------------|-------------|-------------|----------|--|
| 31 | 150-15 内圆板 |  | 158-15 | 150-15 | 16 | | 640 | |
| 32 | 200-12 内圆板 |  | 204-12 | 200-12 | 15支 | 21*18cm | 840 | |
| 33 | 200-15 海浪板 |  | 208-15 | 205-15 | 12 | 18*21.5cm | 830 | |
| 34 | 200-15 凸海浪板 |  | 209-15 | 200-15 | 16支 | 21*21cm | 880 | |
| 35 | 200-12 凹海浪板 |  | 205-12 | 200-12 | 16 | | 800 | |

| No. | Items | Photo | Real size | Usage Size | Pcs/ Carton | Carton size | Weight/M | |
|-----|-----------------|---|-----------|------------|-------------|-------------|----------|--|
| 36 | 200-15 凹海浪板 |  | 208-15 | 200-15 | 18支 | 21.5*21cm | 860 | |
| 37 | 150-15 中空波浪板 |  | 159-14 | 150-14 | 16 | 16*23cm | 650 | |
| 38 | 125-12 实心格栅 |  | 125-12 | 120-12 | 22 | 13*19cm | 550 | |
| 39 | 195-10 异形格栅 |  | 203-10 | 195-10 | 15支 | 21*15cm | 800 | |
| 40 | 150-14 双联格栅 |  | 159-14 | 150-14 | 14支 | 16.3*19cm | 680 | |

| No. | Items | Photo | Real size | Usage Size | Pcs/ Carton | Carton size | Weight/M | |
|-----|--------------|--|-----------|------------|-------------|-------------|----------|--|
| 41 | 50-50 方通 |  | 50-50 | | 16支 | 21*21cm | 550 | |
| 42 | 100-50 方通 |   | 100-50 | | 10支 | 20.5*27cm | 860 | |
| 43 | 25-25 直角 |   | 25-25 | | 120 | 13*17cm | 120 | |
| 44 | 150-50 方通 |   | 150-50 | | 5支 | 16*26cm | 1700 | |
| 45 | 10-20 阳角 |  | 10-20 | | 100支 | 13*17cm | 100 | |

Co-extrusion decking/ wall cladding

Wechat/Whatsapp: +8618866930785 Email: andy@jikewood.com

| 编号 Number | 产品图片 Picture | 货号 Item No.: | 规格图 Model drawings | 宽度 Width(mm) | 厚度 Thickness(mm) | 产品名称 Product name | 米重(公斤/ 米) Weight (Kg/ m) | 备注 |
|--------------------------------|---|------------------|---|-----------------|---------------------|----------------------|-----------------------------------|----|
| Co extrusion floor 共挤地板 | | | | | | | | |
| 1 |  | AL-GS70-1 1B |  | 70 | 11 | 共挤桑拿板 Fence Board | 1.02 | |
| 2 |  | AL-GS140- 22C |  | 140 | 22 | 共挤地板 | 2.96 | |
| 3 |  | AL-GK140- 23C |  | 140 | 23 | 共挤地板, 可 单/双色 | 2.74 | |
| 4 |  | AL-GK140- 25A |  | 140 | 25 | 共挤地板 | 2.66 | |
| 5 |  | AL-GK145- 21C |  | 145 | 21 | 共挤地板 | 2.26 | |
| 6 |  | AL-GK148- 22A |  | 148 | 22 | 双色共挤 | 2.75 | |

| | | | | | | | | |
|----|---|----------------|---|-------|-----|--------------------------------|------|----------|
| 7 |  | AL-GS140-23A |  | 140 | 23 | 实心共挤地板 Co extruded flooring | 3.96 | |
| 8 |  | AL-GS70-10E |  | 70 | 10 | 共挤桑拿板 Fence Board | 0.63 | |
| 9 |  | AL-GK100-20B |  | 100 | 20 | 共挤三孔板 | 1.45 | |
| 10 | | AL-GK60-42B |  | 60 | 42 | 共挤两孔板 (可配注塑盖子) | 1.13 | |
| 11 |  | AL-GK100-50C |  | 100 | 50 | 共挤三孔板 (可配注塑盖子) | 2.34 | |
| 12 | | AL-GK120-62A |  | 120 | 62 | 共挤三孔板 (可配注塑盖子) | 2.9 | |
| 13 |  | AL-GK100-100C |  | 100 | 100 | 共挤立柱 | 4.64 | |
| 14 |  | AL-GK161.5-20C |  | 161.5 | 20 | 共挤栅栏板 | 2.2 | 有效宽度 148 |
| 15 |  | AL-GS117-20A | | 117 | 20 | 共挤墙板 | 1.6 | |

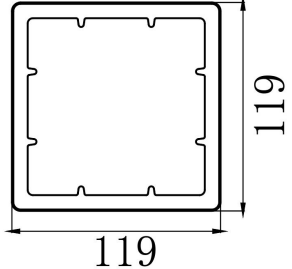
| | | | | | | | | |
|----|--|---------------|--|-----|-----|---------|------|--|
| 16 | | AL-GK120-120C |  | 119 | 119 | 全覆盖共挤立柱 | 5.34 | |
|----|--|---------------|--|-----|-----|---------|------|--|

Co extrusion Wall panel 共挤墙板

| | | | | | | | | |
|----|---|----------------|---|-----|------|--------------|------|----------|
| 17 |  | AL-GK169-26A |  | 169 | 26 | 共挤长城板 | 2.19 | 有效宽度 150 |
| 18 |  | AL-GK195-20A |  | 195 | 20 | 共挤围栏板 长城板 | 2.32 | 有效宽度 187 |
| 19 |  | AL-GK220-26A |  | 220 | 26 | 共挤长城板 | 2.95 | 有效宽度 202 |
| 20 |  | AL-GK219-26A |  | 219 | 26 | 共挤长城板 | 3.0 | 有效宽度 199 |
| 21 |  | AL-GK219-26F |  | 219 | 26 | 共挤长城板 | 2.69 | 有效宽度 200 |
| 22 |  | AL-GK219-26C |  | 219 | 26 | 共挤长城板 | 3.0 | 有效宽度 199 |
| 23 |  | AL-GK245-33.5D | | 245 | 33.5 | 共挤 长城板 | 4.0 | 有效宽度 225 |
| 24 |  | AL-GK219-30A |  | 219 | 30 | 共挤长城板 | 2.77 | 有效宽度 199 |





JIKE
Industry Chains

First generation WPC decking/wall cladding

Wechat/Whatsapp: +8618866930785 Email: andy@jikewood.com

| 编号 Number | 产品图片 Picture | 货号 Item No. : | 规格图 Model drawings | 宽度 Width(mm) | 厚度 Thickness(mm) | 产品名称 Product name | 米重(公斤/米) Weight (Kg/m) | 备注 |
|--------------------------|-----------------|---------------------|-----------------------|-----------------|---------------------|--------------------------|---------------------------|----|
| Hollow floor 空心地板 | | | | | | | | |
| 1 | | AL-K135-25A | | 135 | 25 | 空心地板 (可离线压花) | 2.40 | |
| 2 | | AL-K135-25B | | 135 | 25 | 空心地板 (在线压花尺寸, 普通尺寸-3) | 2.53 | |
| 3 | | AL-K135-25C | | 135 | 25 | 空心地板 Hollow Decking | 2.44 | |
| 4 | | AL-K138-39A | | 138 | 39 | 空心地板 Hollow Decking | 3.29 | |
| 5 | | AL-K140-20A | | 140 | 20 | 空心地板 (在线压花尺寸, 普通尺寸-3) | 2.04 | |
| 6 | | AL-K140-24A | | 140 | 24 | 空心地板 (在线压花尺寸, 普通尺寸-3) | 2.22 | |

| | | | | | | | | |
|----|---|-------------|---|-----|----|--------------------------------|------|--|
| 7 |  | AL-K140-25A |  | 140 | 25 | 空心地板 Hollow Decking | 2.28 | |
| 8 |  | AL-K140-25G |  | 140 | 25 | 空心地板 Hollow Decking | 2.41 | |
| 9 |  | AL-K140-25L |  | 140 | 25 | 空心地板 (在线压花尺寸, 普通尺寸-3) | 2.5 | |
| 10 |  | AL-K140-25N |  | 140 | 25 | 空心地板 Hollow Decking | 2.41 | |
| 11 |  | AL-K140-25P |  | 140 | 25 | 空心地板 (在线压花尺寸, 普通尺寸-3) | 2.7 | |
| 12 |  | AL-K140-25R |  | 140 | 25 | 空心地板 Hollow Decking(可印花) | 2.47 | |
| 13 |  | AL-K140-25U |  | 140 | 25 | 空心地板 Hollow Decking | 2.68 | |
| 14 |  | AL-K140-30A |  | 140 | 30 | 空心地板 Hollow Decking | 2.63 | |

| | | | | | | | | |
|----|---|-------------|---|-----|----|--------------------------|------|--|
| 15 |  | AL-K140-40A |  | 140 | 40 | 空心地板 Hollow Decking | 3.4 | |
| 16 |  | AL-K145-20A |  | 145 | 20 | 空心地板 (在线压花尺寸, 普通尺寸-3) | 2.12 | |
| 17 |  | AL-K145-25B |  | 145 | 25 | 空心地板 Hollow Decking | 2.57 | |
| 18 |  | AL-K145-25C |  | 145 | 25 | 空心地板 (在线压花尺寸, 普通尺寸-3) | 2.56 | |
| 19 |  | AL-K145-25D |  | 145 | 25 | 空心地板 (可离线印花) | 2.58 | |
| 20 |  | AL-K145-30A |  | 145 | 30 | 空心地板 Hollow Decking | 2.89 | |
| 21 |  | AL-K145-30B |  | 145 | 30 | 空心地板 Hollow Decking | 3.15 | |
| 22 |  | AL-K146-24A |  | 146 | 24 | 空心地板 Hollow Decking | 2.38 | |
| 23 |  | AL-K146-25A |  | 146 | 25 | 空心地板 (在线压花尺寸, 普通尺寸-3) | 2.72 | |

| | | | | | | | | |
|----|---|-----------------|---|-----|----|--------------------------------|------|--|
| 24 |  | AL-K146 -25B |  | 146 | 25 | 空心地板 (在线压花尺寸, 普通尺寸-3) | 2.92 | |
| 25 |  | AL-K148 -25C |  | 148 | 25 | 空心地板 Hollow Decking(可印花) | 2.75 | |
| 26 |  | AL-K150 -20A |  | 150 | 20 | 空心地板 Hollow Decking | 2.18 | |
| 27 |  | AL-K150 -25A |  | 150 | 25 | 空心地板 Hollow Decking | 2.86 | |
| 28 |  | AL-K150 -25B |  | 150 | 25 | 空心地板 Hollow Decking | 2.55 | |
| 29 |  | AL-K150 -25D |  | 150 | 25 | 空心地板 Hollow Decking | 2.62 | |
| 30 |  | AL-K150 -25E |  | 150 | 25 | 空心地板 Hollow Decking | 2.55 | |
| 31 |  | AL-K150 -50B |  | 150 | 50 | 空心地板 Hollow Decking | 3.85 | |
| 32 |  | AL-K150 -50D |  | 150 | 50 | 空心地板 Hollow Decking(可印花) | 3.92 | |

| | | | | | | | | |
|----|---|-------------------|---|-----|------|---------------------------------|------|--|
| 33 |  | AL-K200 -30A |  | 200 | 30A | 空心板 Hollow Decking(可印花) | 4.11 | |
| 34 |  | AL-K299 -16A |  | 299 | 16 | 空心地板 Hollow Decking | 4.03 | |
| 35 |  | AL-K120 -30A |  | 120 | 30 | 空心地板 (在线压花尺寸, 普通尺寸-3) | 2.73 | |
| 36 |  | AL-K140 -25B |  | 140 | 25 | 六圆孔地板 (可印花) (在线压花尺寸, 普通尺寸-3) | 3.27 | |
| 37 |  | AL-K140 -25D |  | 140 | 25 | 六圆孔地板 Round holes Decking | 2.73 | |
| 38 |  | AL-K140 -25J |  | 140 | 25 | 六圆孔地板 Round holes Decking | 2.71 | |
| 39 |  | AL-K140 -23.5K |  | 140 | 23.5 | 六圆孔地板 (在线压花尺寸, 普通尺寸-3) | 2.89 | |
| 40 |  | AL-K140 -25M |  | 140 | 25 | 六圆孔地板 Round holes Decking | 2.52 | |
| 41 |  | AL-K140 -25Q |  | 140 | 25 | 六圆孔地板 Round holes Decking | 2.53 | |

| | | | | | | | | |
|----|---|---------------------|---|-----|----|---------------------------------|------|--|
| 42 |  | AL-S140 -25S |  | 140 | 25 | 六圆孔地板 Round holes Decking | 2.66 | |
| 43 |  | AL-K140 -25T |  | 140 | 25 | 六圆孔地板 Round holes Decking | 2.62 | |
| 44 |  | AL-K140 -30B |  | 140 | 30 | 五圆孔地板 (在线压花尺寸, 普通尺寸-3) | 3.23 | |
| 45 |  | AL-K140 -30C |  | 140 | 30 | 五圆孔地板 Round holes Decking | 3.02 | |
| 46 |  | AL-K145 -21A |  | 145 | 21 | 七圆孔地板 Round holes Decking | 2.84 | |
| 47 |  | AL-K145 -23A |  | 145 | 23 | 六圆孔地板 (在线压花尺寸, 普通尺寸-3) | 2.85 | |
| 48 |  | AL-K146 -23A |  | 146 | 23 | 七圆孔地板 Round holes Decking | 2.92 | |
| 50 |  | AL-K148 -23B |  | 148 | 23 | 七圆孔地板 (在线压花尺寸, 普通尺寸-3) | 2.7 | |
| 51 |  | AL-K1 48-23 C |  | 148 | 23 | 七圆孔地板 | 2.67 | |





| | | | | | | | | |
|----|--|-------------|--|-----|----|-------|------|--|
| 52 | | AL-K150-40A | | 150 | 40 | 四圆孔地板 | 3.75 | |
| 53 | | AL-K150-50C | | 150 | 50 | 三圆孔地板 | 4.55 | |

Wood-plastic solid floor 木塑实心地板

| | | | | | | | | |
|----|--|---------------|--|-----|------|----------------------------|------|--|
| 54 | | AL-S75-25A | | 75 | 25 | 实心地板(可印花) Solid Decking | 2.32 | |
| 55 | | AL-S100-21A | | 100 | 21 | 实心地板(可印花) Solid Decking | 2.59 | |
| 56 | | AL-S140-18A | | 140 | 18 | 实心地板 Solid Decking | 3.13 | |
| 57 | | AL-S140-20A | | 140 | 20 | 实心地板 (在线压花尺寸, 普通尺寸-3) | 3.55 | |
| 58 | | AL-S140-22A | | 140 | 22 | 实心地板(在线压花尺寸, 普通尺寸-3) | 3.87 | |
| 59 | | AL-S140-22.7A | | 140 | 22.7 | 实心地板(可印花) Solid Decking | 3.93 | |

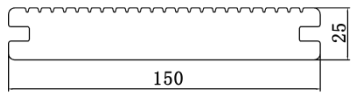
| | | | | | | | | |
|----|---|-------------|---|-----|----|---|------|--|
| 60 | | AL-S140-23E |  | 140 | 23 | 实木地板(可印花) Solid Decking | 3.32 | |
| 61 |  | AL-S140-25A |  | 140 | 25 | 实木地板(可印花) Solid Decking (It can be embossed) | 4.41 | |
| 62 |  | AL-S140-25B |  | 140 | 25 | 实木地板 Solid Decking | 4.44 | |
| 63 |  | AL-S140-25C |  | 140 | 25 | 实木地板 Solid Decking | 4.02 | |
| 64 |  | AL-S140-25D |  | 140 | 25 | 实木地板 Solid Decking | 4.08 | |
| 65 |  | AL-S140-25E |  | 140 | 25 | 多功能实心板 | 4.65 | |
| 66 |  | AL-S140-25F |  | 140 | 25 | 实木地板 Solid Decking | 3.77 | |
| 67 |  | AL-S140-25G |  | 140 | 25 | 实木地板 Solid Decking | 4.48 | |

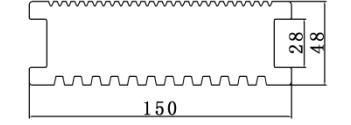
| | | | | | | | | |
|----|---|-------------|---|-----|----|---|------|--|
| 68 |  | AL-S140-30A |  | 140 | 30 | 实木地板 Solid Decking (It can be embossed) | 5.0 | |
| 69 |  | AL-S140-35A |  | 140 | 35 | 实木地板 Solid Decking (It can be embossed) | 5.38 | |
| 70 |  | AL-S140-37A |  | 140 | 37 | 实木地板 Solid Decking (It can be embossed) | 6.14 | |
| 71 |  | AL-S140-40A |  | 140 | 40 | 实木地板(可印花) Solid Decking (It can be embossed) | 7.5 | |
| 72 |  | AL-S140-40B |  | 140 | 40 | 实木地板 Solid Decking (It can be embossed) | 6.63 | |
| 73 |  | AL-S140-40C |  | 140 | 40 | 实木地板 Solid Decking (It can be embossed) | 6.63 | |
| 74 |  | AL-S140-40D |  | 140 | 40 | 实木地板 Solid Decking (It can be embossed) | 7.26 | |
| 75 |  | AL-S145-20A |  | 145 | 20 | 多功能实心板 Multifunctional Solid Board | 3.92 | |

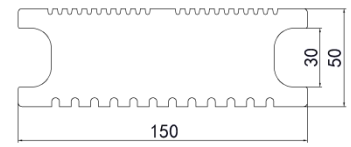
| | | | | | | | | |
|----|---|-------------|---|-----|----|--|------|--|
| 76 |  | AL-S150-25A |  | 150 | 25 | 实木地板 Solid Decking (It can be embossed) | 4.71 | |
| 77 |  | AL-S150-48A |  | 150 | 48 | 实木地板 Solid Decking (It can be embossed) | 8.2 | |
| 78 |  | AL-S150-50B |  | 150 | 50 | 实木地板 Solid Decking (It can be embossed) | 8.19 | |



Wallboard 墙板系列

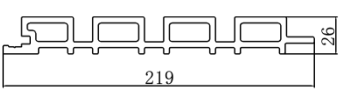

| | | | | | | | | |
|----|---|---------------|---|-----|------|------------------------|------|-----------------------|
| 79 |  | AL-K100-20A |  | 100 | 20 | 墙板 (在线压花尺寸, 普通尺寸-3) | 1.34 | |
| 80 |  | AL-S120-13A |  | 120 | 13 | 墙板 Wall Panel (可印花) | 1.64 | 有效宽度 106 |
| 81 |  | AL-S148-21A |  | 148 | 21 | 墙板 Wall Panel (可印花) | 1.56 | 有效宽度 125 价, 模具 3 副 |
| 82 | | AL-S156-20.5A |  | 156 | 20.5 | 墙板 Wall Panel (可印花) | 1.47 | 有效宽度 138 |
| 83 | | AL-S156-20.5B |  | 156 | 20.5 | 墙板 Wall Panel (可印花) | 1.51 | 只能做砂光, 有效宽度 134 |
| 84 |  | AL-S156-21A |  | 156 | 21 | 墙板 (在线压花尺寸, 普通尺寸-3) | 1.83 | 有效宽度 135 模具 2 副 |

| | | | | | | | | |
|----|---|---------------|---|--------|-------|----------------------------------|------|--------------|
| 85 |  | AL-K160-18A |  | 160 | 18 | 墙板 Wall Pane | 1.86 | 有效宽度 145 |
| 86 |  | AL-K161.5-20A |  | 161.5 | 20 | 墙板 Wall Pane (在线压花尺寸, 普通尺寸-3) | 2.25 | 在线压花有效宽度 148 |
| 87 |  | AL-K169-28A |  | 169 | 28 | 一代长城板 | 2.37 | 有效宽度 149 |
| 88 |  | AL-K172-28A |  | 172.25 | 28.31 | 斜面板 Inclined Panel | 2.46 | 有效宽度 144 |
| 89 |  | AL-K173-36A |  | 173 | 36 | 墙板 Wall Panel | 3.75 | 有效宽度 163 |
| 90 |  | AL-K180-28A |  | 180 | 28 | 瓦片 Inclined Panel | 2.72 | 有效宽度 153 |
| 91 |  | AL-K180-25A |  | 180 | 25 | 墙板 Wall Pane | 2.35 | 有效宽度 169 |
| 92 |  | AL-K205-20A |  | 205 | 20 | 墙板 Wall Pane | 2.77 | 有效宽度 195 |
| 93 |  | AL-K205-20B |  | 205 | 20 | 墙板 Wall Pane | 2.9 | 有效宽度 190 |
| 94 |  | AL-K205-20P |  | 205 | 20 | 墙板 Wall Pane | 3.03 | 有效宽度 177 |

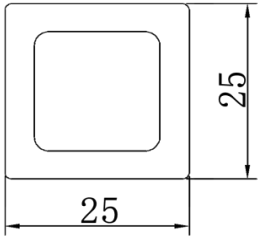
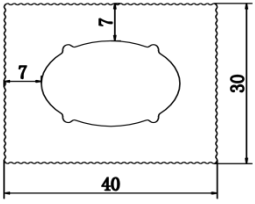
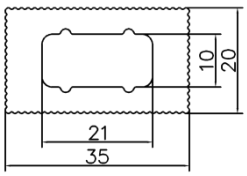
| | | | | | | | | |
|----|---|-------------|---|-----|----|-----------------|------|------------------|
| 95 |  | AL-K205-21A |  | 205 | 21 | 墙板 Wall Pane | 2.82 | 有效宽度 195 |
| 96 |  | AL-K192-13A |  | 192 | 13 | 一代长城板 | 1.68 | 有效宽度 178 |
| 97 |  | AL-K200-17A |  | 200 | 17 | 一代长城板 | 2.21 | 有效宽度 178 |
| 98 |  | AL-K218-28A |  | 218 | 28 | 一代长城板 | 3.14 | 有效宽度 200 模具 5 |
| 99 |  | AL-K219-26B |  | 219 | 26 | 一代长城板 | 2.92 | 有效宽度 200 |

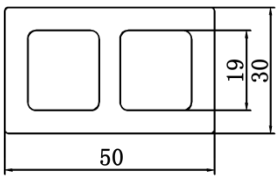
Column、Guardrail、Gallery frame 立柱、护栏、廊架系列

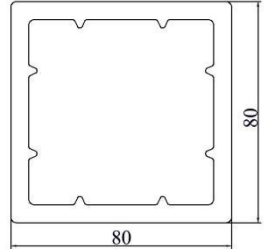









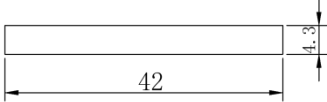

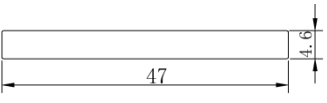
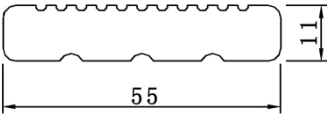

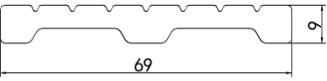
| | | | | | | | | |
|-----|---|------------|---|----|----|---------------|------|--|
| 100 |  | AL-K25-25A |  | 25 | 25 | 小方管 Column | 0.46 | |
| 101 | | AL-K40-30A |  | 40 | 30 | 小方管 Column | 1.12 | |
| 102 | | AL-K35-20A |  | 35 | 20 | 小方管 Column | 0.63 | |
| 103 |  | AL-K50-30B |  | 50 | 30 | 小方管 Column | 1.15 | |

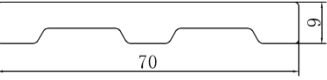
| | | | | | | | | |
|-----|---|--------------|---|-----|-----|-------------------------|------|--|
| 104 |  | AL-K50-50A |  | 50 | 50 | 小方管 Column | 1.3 | |
| 105 |  | AL-K80-80A |  | 80 | 80 | 立柱 Hollow Post | 2.67 | |
| 106 |  | AL-K83-32A |  | 83 | 32 | 方管 Column | 1.63 | |
| 107 |  | AL-K90-90A |  | 90 | 90 | 立柱 (内腔用 40*40 柱脚) | 5.20 | |
| 108 |  | AL-K100-100A |  | 100 | 100 | 立柱 (内腔用 50*50 柱脚) | 5.12 | |
| 109 |  | AL-K120-120A |  | 120 | 120 | 立柱 (内腔用 60*60 柱脚) | 6.45 | |
| 110 |  | AL-K150-150A |  | 150 | 150 | 立柱 (内腔用 80*80 柱脚) | 9.86 | |

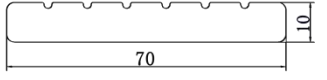
| | | | | | | | | |
|-----|---|--------------|---|-----|-----|---------------------------|-------|--|
| 111 |  | AL-K150-150B |  | 150 | 150 | 立柱 (内腔用 50*50 柱脚) | 9.07 | |
| 112 |  | AL-K200-200A |  | 200 | 200 | 立柱 (内腔用 120*120 柱脚) | 14.97 | |
| 113 |  | AL-K101-101A |  | 101 | 101 | 四槽立柱 (内腔用 50*50 柱脚) | 5.06 | |
| 114 |  | AL-K101-101B |  | 101 | 101 | 双槽立柱 (内腔用 40*40 柱脚) | 5 | |
| 115 | | AL-K101-101C |  | 101 | 101 | 三槽立柱 (内腔用 40*40 柱脚) | 5.16 | |
| 116 |  | AL-K91-46A |  | 91 | 46 | 扶手 Armrest | 2.52 | |
| 117 |  | AL-K80-50A |  | 80 | 50 | 扶手 Armrest | 2.22 | |

| | | | | | | | | |
|-----|---|-------------|---|-----|----|-------------------------|------|--|
| 118 |  | AL-K60-40A |  | 60 | 40 | 方管 Square Pipe | 1.55 | |
| 119 |  | AL-K60-40B |  | 60 | 40 | 方管 Square Pipe | 1.2 | |
| 120 | | AL-K60-42C |  | 60 | 42 | 方管 可配注塑盖子 | 1.4 | |
| 121 |  | AL-K100-20B |  | 100 | 20 | 三孔板 | 1.45 | |
| 122 |  | AL-K100-30A |  | 100 | 30 | 三孔板 Three-hole Board | 1.55 | |
| 123 |  | AL-K100-50A |  | 100 | 50 | 三孔板 Three-hole Board | 2.85 | |
| 124 | | AL-K100-50D |  | 100 | 50 | 三孔板 可配注塑盖子 | 2.36 | |
| 125 | | AL-K150-21A |  | 150 | 21 | 四孔板 Four-hole plate | 2.42 | |
| 126 |  | AL-K150-60A |  | 150 | 60 | 三孔板 Three-hole Board | 3.34 | |

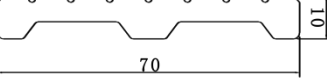

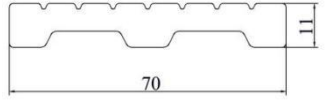



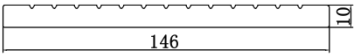



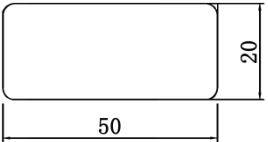

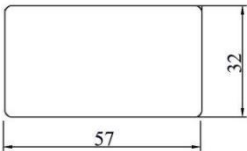

| | | | | | | | | |
|-------------------|---|--------------|---|-----|-----|---|------|---------|
| 127 |  | AL-K150-60B |  | 150 | 60 | 三孔板 Three-hole Board | 3.67 | |
| 128 |  | AK-K160-60A |  | 160 | 60 | 刀片 (内腔用 40*60 钢衬) | 4.00 | |
| 129 |  | AL-K160-80A |  | 160 | 80 | 刀片 (内腔用 60*60 钢衬) | 5.35 | |
| 130 | | AL-K200-50A |  | 200 | 50 | 五孔板(不能 压花、穿钢) | 3.78 | |
| 131 |  | AL-K200-80A |  | 200 | 80 | 刀片 (双内腔用 60*60 钢衬) | 6.09 | |
| 132 |  | AL-K200-100A |  | 200 | 100 | 刀片 (内腔用 80*80 钢衬) | 7.85 | |
| 133 |  | AL-K220-60A |  | 220 | 60 | 刀片 (内腔用 40*60 钢衬, 仅能宽面砂) | 6.02 | |
| Sauna Board 桑拿板系列 | | | | | | | | |
| 134 |  | AL-S30-4A |  | 30 | 4 | 桑拿板 Fence Board | 0.18 | (不单独销售) |
| 135 |  | AL-S40-4A |  | 40 | 4 | 桑拿板 Fence Board | 0.24 | (不单独销售) |

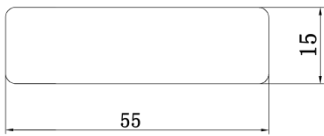

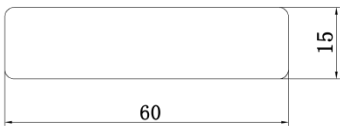

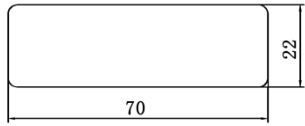

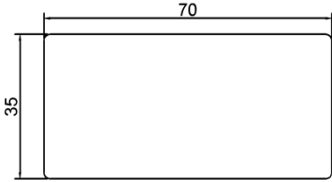

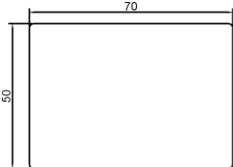

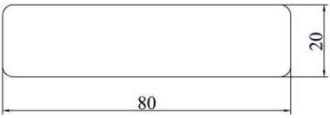

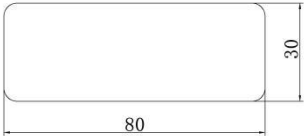

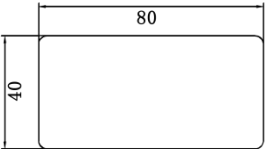
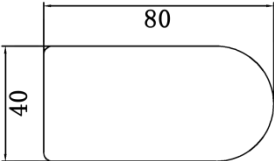
| | | | | | | | | |
|-----|---|------------|---|----|----|-----------------------|------|---------|
| 136 |  | AL-S42-4A |  | 42 | 4 | 桑拿板 Fence Board | 0.24 | (不单独销售) |
| 137 |  | AL-S47-4A |  | 47 | 4 | 桑拿板 Fence Board | 0.29 | (不单独销售) |
| 138 | | AL-S55-11A |  | 55 | 11 | 桑拿板 Fence Board | 0.75 | |
| 139 |  | AL-S69-9A |  | 69 | 9 | 桑拿板 Fence Board | 0.62 | |
| 140 |  | AL-S70-9A |  | 70 | 9 | 桑拿板 Fence Board (可印花) | 0.65 | |
| 141 |  | AL-S70-10A |  | 70 | 10 | 桑拿板 Fence Board (可印花) | 0.9 | |
| 142 |  | AL-S70-10B |  | 70 | 10 | 桑拿板 Fence Board (可印花) | 0.7 | |
| 143 |  | AL-S70-10D |  | 70 | 10 | 桑拿板 Fence Board | 0.67 | |
| 144 |  | AL-S70-11A |  | 70 | 11 | 桑拿板 Fence Board | 0.82 | |

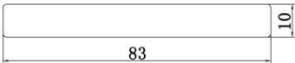

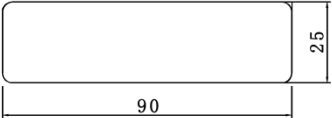



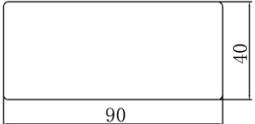

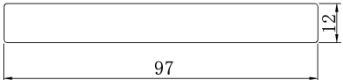

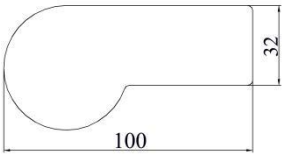

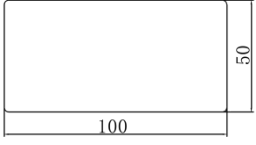

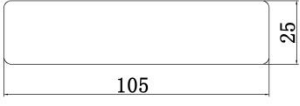

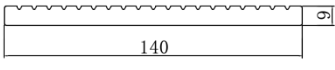
| | | | | | | | | |
|-----|---|-------------|---|-----|-----|---------------------------|------|--|
| 145 |  | AL-S70-11C |  | 70 | 11 | 桑拿板 Fence Board | 0.73 | |
| 146 |  | AL-S71-10B |  | 71 | 10 | 桑拿板 (DIY 仅可离线印花) | 0.75 | |
| 147 |  | AL-S72-10A |  | 72 | 10 | 桑拿板 Fence Board | 0.7 | |
| 148 |  | AL-S72-11A |  | 72 | 11 | 桑拿板条 (适合做栅栏等) Fence Board | 1.00 | |
| 149 |  | AL-S72-11B |  | 72 | 11 | 桑拿板 Fence Board | 0.81 | |
| 150 |  | AL-S72-12A |  | 72 | 12 | 桑拿板 (DIY 仅可离线印花) | 1.12 | |
| 151 |  | AL-S73-7A |  | 73 | 7 | 桑拿板 Fence Board | 0.66 | |
| 152 |  | AL-S95-9.4A |  | 95 | 9.4 | 桑拿板 (在线压花尺寸, 普通尺寸-3) | 1.11 | |
| 153 |  | AL-S142-10A |  | 142 | 10 | 实心板 (在线压花尺寸, 普通尺寸-3) | 1.85 | |

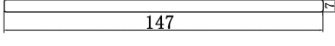

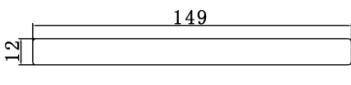

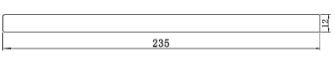

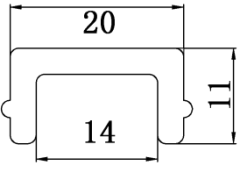

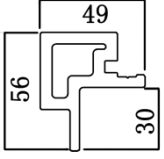

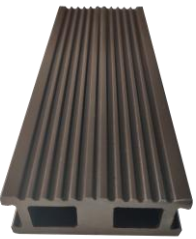
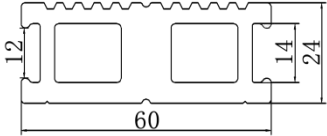
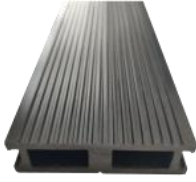
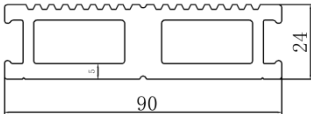

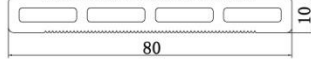
| | | | | | | | |
|-----|--|-------------|---|-----|----|---------------------|------|
| 154 |  | AL-S146-10A |  | 146 | 10 | 实心板（在线压花尺寸, 普通尺寸-3） | 1.91 |
|-----|--|-------------|---|-----|----|---------------------|------|

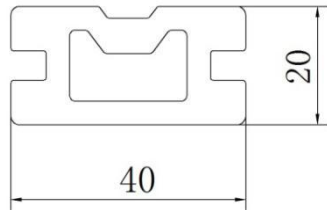

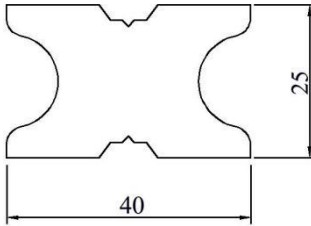

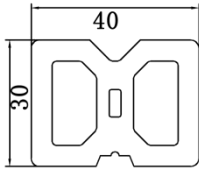

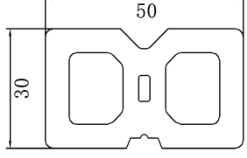
Bench bar 凳条系列

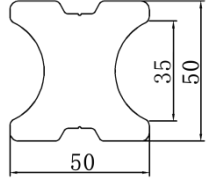
| | | | | | | | |
|-----|---|------------|---|----|----|-------------|------|
| 155 |  | AL-S50-20A |  | 50 | 20 | 凳条 Bench | 1.32 |
| 156 |  | AL-S50-50B |  | 50 | 50 | 凳条 Bench | 3.31 |
| 157 |  | AL-S57-32A |  | 57 | 32 | 凳条 Bench | 2.48 |
| 158 |  | AL-S55-15A |  | 55 | 15 | 凳条 Bench | 1.1 |
| 159 |  | AL-S60-15A |  | 60 | 15 | 凳条 Bench | 1.2 |
| 160 |  | AL-S70-22A |  | 70 | 22 | 凳条 Bench | 2.05 |
| 161 |  | AL-S70-35A |  | 70 | 35 | 凳条 Bench | 3.26 |
| 162 |  | AL-S70-50A |  | 70 | 50 | 凳条 Bench | 4.65 |

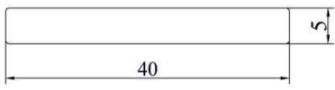
| | | | | | | | | |
|-----|---|------------|---|----|----|--------------|------|--|
| 163 |  | AL-S80-20A |  | 80 | 20 | 凳条 Bench | 2.11 | |
| 164 |  | AL-S80-30A |  | 80 | 30 | 凳条 Bench | 3.18 | |
| 165 |  | AL-S80-40A |  | 80 | 40 | 凳条 Bench | 4.25 | |
| 166 | | AL-S80-40B |  | 80 | 40 | 凳条 Bench | 4.03 | |
| 167 |  | AL-S83-10A |  | 83 | 10 | 实心条 Bench | 1.1 | |
| 168 |  | AL-S90-25A |  | 90 | 25 | 凳条 Bench | 2.98 | |
| 169 |  | AL-S90-30A |  | 90 | 30 | 凳条 Bench | 3.56 | |
| 170 |  | AL-S90-40A |  | 90 | 40 | 凳条 Bench | 4.78 | |
| 171 |  | AL-97-12A |  | 97 | 12 | 实心条 Bench | 1.57 | |

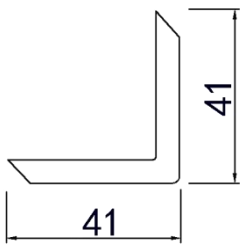
| | | | | | | | | |
|--------------------------|---|-------------|---|-----|----|-------------------------|------|---------|
| 172 |  | AL-S100-32A |  | 100 | 32 | 凳条 Bench | 5.0 | |
| 173 |  | AL-S100-50A |  | 100 | 50 | 凳条 Bench | 6.6 | |
| 174 |  | AL-S105-25A |  | 105 | 25 | 凳条 Bench | 3.53 | |
| 175 |  | AL-S140-9A |  | 140 | 9 | 实心条 (在线压花尺寸, 普通尺寸-3) | 1.64 | |
| 176 |  | AL-S147-7A |  | 147 | 7 | 实心条 Bench | 1.09 | |
| 177 |  | AL-S149-12A |  | 149 | 12 | 实心条 (在线压花尺寸, 普通尺寸-3) | 2.41 | |
| 178 |  | AL-S235-12A |  | 235 | 12 | 实心条 Bench | 3.75 | |
| Other series 其它系列 | | | | | | | | |
| 179 |  | AL-S20-11A |  | 20 | 11 | 卡条 | 0.15 | (不单独销售) |
| 180 |  | AL-K49-56A |  | 49 | 56 | 转角 | 1.17 | (不单独销售) |

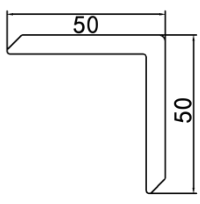
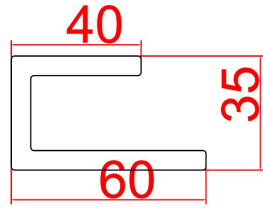
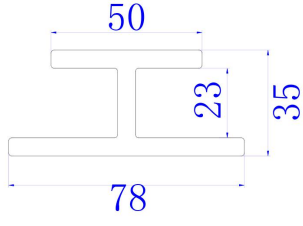
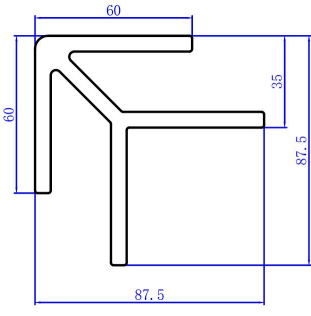
| | | | | | | | | |
|-----|---|----------------|---|----|----|---------------------------|------|--|
| 181 |  | AL-K60* 24A |  | 60 | 24 | 附框 | 1.12 | |
| 182 |  | AL-K90* 24A |  | 90 | 24 | 附框 | 1.49 | |
| 183 |  | AL-K80- 10A |  | 80 | 10 | 空心地板 Hollow Decking | 0.69 | |
| 184 |  | AL-K40- 20A |  | 40 | 20 | 龙骨 Solid joist | 0.71 | |
| 185 |  | AL-S40- 25A |  | 40 | 25 | 龙骨 Solid joist | 1.00 | |
| 186 |  | AL-K40- 30B |  | 40 | 30 | 龙骨 Solid joist | 0.97 | |
| 187 |  | AL-K50- 30A |  | 50 | 30 | 龙骨 Solid joist | 1.27 | |
| 188 |  | AL-S50- 50C |  | 49 | 49 | 龙骨 Solid joist | 2.22 | |

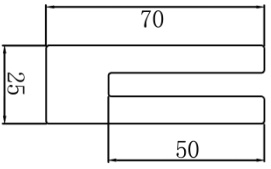
| | | | | | | | | |
|-----|---|------------|---|----|----|---------------------|------|---------|
| 189 |  | AL-S40-5A |  | 40 | 5 | 实心板 Armrest | 0.30 | (不单独销售) |
| 190 |  | AL-S41-41A |  | 41 | 41 | 封边条 Edge banding | 0.55 | (不单独销售) |
| 191 |  | AL-S50-50D |  | 50 | 50 | 封边条 Edge banding | 0.73 | (不单独销售) |
| 192 | | AL-S60-35A |  | 60 | 35 | 封边条 Edge banding | 0.98 | (不单独销售) |
| 193 | | AL-S78-35A |  | 78 | 35 | 工字梁 | 1.2 | (不单独销售) |
| 194 | | AL-S88-88A |  | 88 | 88 | 封边条 Edge banding | 2.06 | (不单独销售) |
| 195 |  | AL-S70-25A |  | 70 | 25 | 卡条 | 1.89 | |

| | | | | | | | |
|---------------------------|---|-------------|---|-----------|--|---------------------|---|
| 196 |  | AL-S72-21A |  | 72 | 21 | 封边 | 1.03 |
| 197 | | AL-S72-21B |  | 72 | 21 | 封边 | 1.0 |
| 198 |  | AL-K146-45B |  | 146 | 45 | 转角 | 2.91 |
| 199 |  | AL-K146-45A |  | 146 | 45 | 转角 (在线压花尺寸, 普通尺寸-3) | 3.02 |
| 200 |  | AL-K220-25A |  | 220 | 25 | 踏板 | 4.87 |
| 201 |  | AL-S130-40A |  | 130 | 40 | 屋脊 Ridge | 1.78 |
| | | |  | 不锈钢 卡扣 |  | 起始卡扣 |  |
| Our-Tech 木塑 DIY 地板 | | | | | | | |
| 尺寸 (mm) | | 图片 | | 图片 | | | |

300*300*20mm



一代色卡 (12色)



红木色



枫叶红



红棕色



柚木色



浅柚木



黄棕色



浅咖啡



深咖啡



波兰灰



浅灰色



70灰



黑色

一代3D压花色卡



一代表面处理











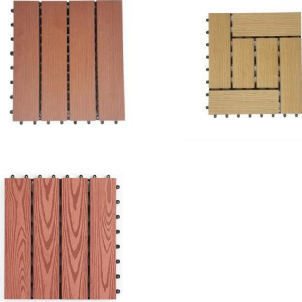

JIKE
Industry Chains

DIY Decking floor

Wechat/Whatsapp: +8618866930785 Email: andy@jikewood.com

| Item No | Product Name | Picture | Length (mm) | Width (mm) | Thickness (mm) | Weight (KG/piece) |
|-------------------------|----------------------------------|---------|-------------|------------|----------------|-------------------|
| DIY Hollow Tiles | | | | | | |
| 1 | DIY Hollow Groove Tiles | | 300 | 300 | 21 | 1.1 |
| 2 | DIY Hollow Hot Sale Groove Tiles | | 300 | 300 | 20 | 0.94 |
| 3 | DIY Hollow Off-line Grain Tiles | | 300 | 300 | 21 | 1.1 |
| 4 | DIY Hollow 3D Wood Grain Tiles | | 300 | 300 | 21 | 1.1 |
| 5 | DIY Hollow Groove Tiles | | 600 | 300 | 20 | 1.88 |
| 6 | DIY Hollow Off-line Tiles | | 600 | 300 | 21 | 2.2 |
| DIY Solid Tiles | | | | | | |
| 7 | DIY Solid Groove Tiles | | 300 | 300 | 22 | 1.3 |

| | | | | | | |
|--------------------------------------|---|---|-----|-----|----|------|
| 8 | DIY Solid Off-line, Grain Tiles |  | 300 | 300 | 22 | 1.3 |
| 9 | DIY Solid 3D Wood Grain Tiles |  | 300 | 300 | 22 | 1.3 |
| 10 | DIY Solid 3D Wood Grain Tiles (3 panels) |  | 300 | 300 | 22 | 1.12 |
| DIY Solid Co-extrusion Tiles | | | | | | |
| 11 | DIY Solid Co-extrusion Tiles |  | 300 | 300 | 22 | 1.4 |
| 12 | DIY Solid Co-extrusion Tiles |  | 600 | 300 | 22 | 2.8 |
| DIY Co-extrusion Hollow Tiles | | | | | | |
| 13 | DIY Hollow Co-extrusion Tiles |  | 300 | 300 | 22 | 0.9 |

| | | | | | | |
|------------------|-------------------------------|--|-----|-----|------|------|
| 14 | DIY Hollow Co-extrusion Tiles |  | 600 | 300 | 22 | 1.8 |
| DIY Edges | | | | | | |
| 15 | DIY Edges |  | 300 | 72 | 19.5 | 1.09 |
| 16 | DIY Groove Edges |  | 300 | 72 | 19.5 | 1.09 |
| DIY Grass | | | | | | |
| 17 | DIY Grass |  | 300 | 300 | 21 | 0.4 |